

# Geoflex PIB

## Installation Handbook

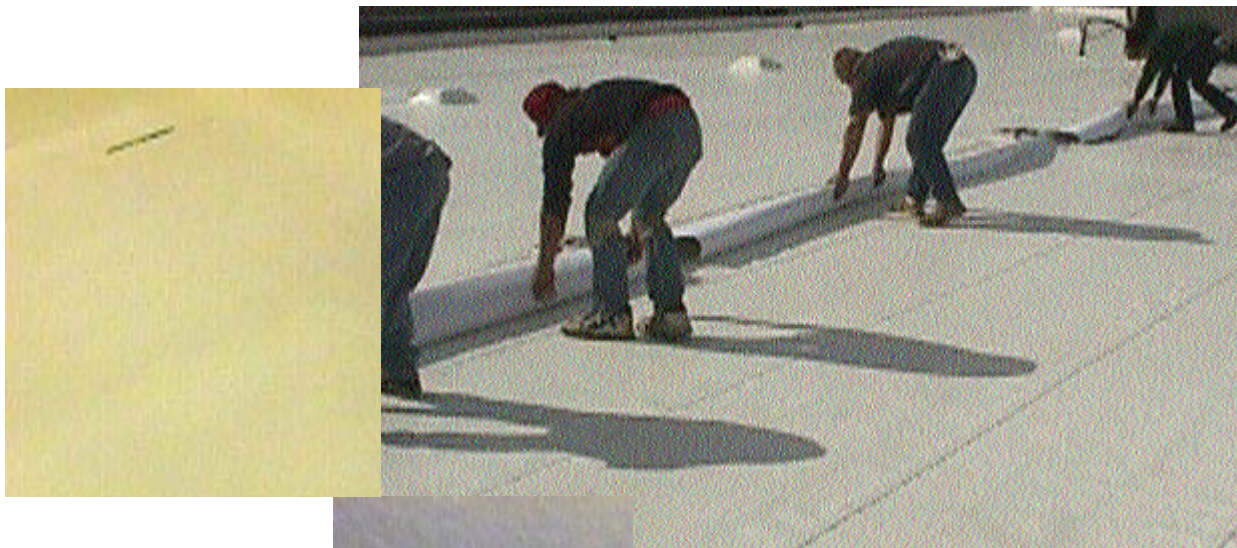

Updated April 1, 2005  
Copyright 2005 Republic Powdered Metals

# Table of Contents

GEOFLEX PIB INSTALLATION MANUAL .....	1
MATERIAL HANDLING, STORAGE & SAFETY .....	2
PRE-INSTALLATION .....	2
RETROFIT APPLICATIONS .....	3
SEAM ASSEMBLY .....	4
ADHESIVE APPLICATION .....	5
• FIELD MEMBRANE APPLICATION	
• VERTICAL FLASHING APPLICATION	
HOT ASPHALT APPLICATION .....	6
CONTINUOUS ENDLAP DETAIL .....	7
STAGGERED ENDLAP DETAIL .....	8
MITERED CORNER WITH A CANT DETAIL .....	9
MITERED CORNER WITHOUT A CANT DETAIL .....	10
INSIDE CORNER DETAIL .....	11
WALL FLASHING DETAIL .....	12
WALL SPLICE DETAIL .....	13
FLASHING TO CYLINDRICAL PENETRATION .....	14
GRAVEL STOP AND GUTTER DETAIL .....	15
DRAIN FLASHING DETAIL .....	16
PITCH POCKET DETAIL .....	17

# Geoflex PIB Installation Manual

Republic Powdered Metals GEOFLEX PIB Single Ply System is designed to provide the customer with a maximum performance roof system, while providing the contractor with unequaled labor efficiency and savings.

## PRODUCT SPECIFICATIONS

Geoflex PIB Single Ply System may be used in a wide variety of roofing applications. As with any roofing installation, application requirements can change from project to project. Because of this, the project specification should always be the primary document for directions as to the proper installation of the Geoflex PIB system. Specifications for Geoflex PIB can be found on Republic's website at [www.rpmrepublic.com](http://www.rpmrepublic.com). This handbook should be used as a reference to provide general application procedures and product information, and should not replace the project specifications.

## TECHNICAL ASSISTANCE

Republic Powdered Metals encourages the use of our Technical Service Personnel for project start ups, in progress inspections, and final project inspection. Republic's Technical Service Personnel will conduct the final inspection at the project, utilizing the current handbook and project specifications.

Republic Powdered Metals reserves the right to demand project start-up assistance.

Republic reserves the right to ensure the contractor has complied with the project specifications, and all other terms and conditions for the issuance of the project warranty.

## CONTACT INFORMATION

Customer Service: 888-742-7759  
Technical Service: 800-551-7081

Customer Service Fax: 888-742-1759  
Technical Service Fax: 800-382-1218

Republic Powdered Metals is a member of the



# Material Handling, Storage & Safety

## MATERIAL HANDLING & STORAGE

- Store GEOFLEX in the original container and protect it from moisture.
- Always store GEOFLEX on its side, never on its end, to prevent edge damage.
- Keep all materials from temperature extremes. Do not allow solvent containing materials to be exposed to high temperatures, open flames or sparks.
- When placing materials on the roof, make sure they are properly protected from the elements and that the weight load is distributed so as to not cause damage to the roof system or deck.

## SAFETY

- Ensure all Federal, State, Provincial and Local regulations are followed in application of this system.
- Follow instructions on the product label and MSDS for proper handling.
- Avoid prolonged inhalation of vapors or contact with eyes or skin. See MSDS or label for instructions.
- Properly dispose of containers when empty.

## Pre-Installation

- GEOFLEX should be installed per project specifications and in keeping with application instructions.
- Approved substrates must be clean, dry, and free of any debris or contaminant.
- Insulation should be properly installed per the system requirements.
- GEOFLEX may be adhered using GEOTAC Adhesive, GEOBOND Field Adhesive, Type III or Type IV asphalt.
- Certain contaminants (Coal Tar Pitch) may require the use of a barrier sheet.
- Minimum ambient application temperature for GEOFLEX PIB is 40 degrees F.
- When installing over an existing roof, **all wet insulation must be removed from existing system and replaced with a comparable thickness, dry insulation** prior to the GEOFLEX PIB membrane being installed.

# Retrofit Applications

- All wet insulation must be removed from existing system and replaced with comparable thickness dry insulation.
- Cut all blisters, fishmouths, etc. allow to dry and re-adhere.
- Cause of roof splits must be determined and corrected before application of new system.
- The roof should be designed so as not to allow ponded water.
- Roof system must be cleaned and all loose gravel removed.
- Apply heavy vented base ply in a floodcoat of hot asphalt or adhere a minimum of 1/2 inch high density wood fiber board.
- Roof deck and structure must meet code standards and be capable of supporting the system according to code requirements.
- The roof system must be completely waterproof at the end of each workday. This can be accomplished by either completing the GEOFLEX roof or properly tying it into the existing system.
- All temporary roofs must be properly tied into the existing waterproofing system to ensure watertight integrity.



Remove loose gravel and clean roof system prior to installation.

# Seam Assembly



1. Align the seam with the bottom of the control numbers to ensure proper seam width.
2. Clean the area to be seamed with a clean, dry lint-free rag.

- The seam area must be dry and free from contamination.
- In cold or damp weather, be sure that moisture does not condense on the cleaned lap. A light wipe with GEOFLEX Solvent is necessary only in case of significant dirt or in humid or cool weather.



3. Remove the release paper from the seam tape. Walk the seam area heel to toe.



4. Roll the seam using the GEOFLEX 35 lbs. Seam Roller to assure complete contact. Apply firm pressure to the Seam Roller.



5. Check the seam with a needle probe. Immediately close any openings using a handroller.

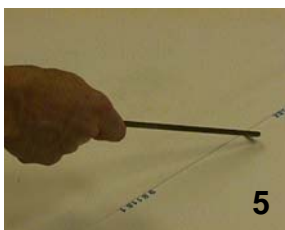

- If necessary, clean any openings with GEOFLEX Solvent and roll the seam firmly together with the GEOFLEX Seam Roller or cover the affected area using Geoflex 5" Cover Tape and paste.

# Adhesive Application

## FIELD MEMBRANE APPLICATION

1. Lay the GEOFLEX cart on level roof surface area and load 3 unopened 5 gallon pails of GEOTAC Adhesive by inserting the base rim of the pail with label facing up into the slot on the cart. Secure latch bar to inside rim of the pail lids.

a. Use GEOBOND Field Adhesive as an alternative adhesive in VOC restricted areas.

2. Open the air vent in the lid of each pail. Punch 3 holes at the marks provided in the bottoms of each pail with the can opener provided with the cart.



3. Center the 9 bead pattern in the area to be covered by the next 42" ply of GEOFLEX membrane. Tip the cart up and pull forward at a pace which lays nine beads of adhesive in 1/4" wide beads (150 sq. ft./gal.). Tip the cart back at the end of the run to stop the adhesive flow.

4. Do not puddle adhesive. Spread puddles with notched squeegee or roller. Apply the GEOFLEX membrane into the wet adhesive and using a clean broom, firmly broom the membrane to the GEOTAC Adhesive (or GEOBOND Field Adhesive) to ensure proper adhesion.

5. At areas within 10' of perimeter 1/2" wide beads should be used (75 sq. ft./gal.) and within 10' of corners 3/4" wide beads (50 sq. ft./gal.). Using a roller or notched squeegee fully adhere at corners and perimeters.

6. Field membrane may be rolled into the adhesive and then seamed or seamed first and then rolled into the adhesive.

## VERTICAL FLASHING APPLICATION

1. Select appropriate width flashing sheet. ( 14", 21", or 28" )

2. Apply GEOTAC Adhesive to the wall at a rate of 75 sq.ft. per gallon.

a. Use GEOBOND Contact Flashing Adhesive as an alternative adhesive in VOC restricted areas.

3. Apply Adhesive to the fleece backing at a rate of 75 sq. ft. per gallon

4. Adhere the GEOFLEX flashing sheet into the GEOTAC Adhesive or GEOBOND Contact Flashing Adhesive when the adhesive is dry to the touch on both surfaces.

# Hot Asphalt Application

- Temperature range of hot asphalt at time of sheet application should be 350 to 400 degrees F.

1. Roll out and position GEOFLEX membrane following guidelines on the membrane.

2. Eliminate wrinkles prior to attachment. Position the sheet so that the guide numbers are visible at the lap for proper seam width.

3. Clean the area to be seamed with a clean, dry lint-free rag.

- a. The seam area must be dry and free from contamination. In cold or damp weather, be sure that moisture does not condense on the cleaned lap. A light wipe with GEOFLEX Solvent is necessary only in case of significant dirt or in humid or cool weather.

4. Clean and roll seam, use seam probe to check for fishmouths.

5. Fold the GEOFLEX sheet lengthwise back to the seam.

6. Pour the hot asphalt using a pour can in a serpentine pattern covering 50% of the area (16 to 18 pounds per square). Start the asphalt pour in the center of the sheet with two persons pouring toward either end.

7. Using five or six men evenly spaced throughout the length of the standard 60' sheet, pick up and apply the GEOFLEX into the hot asphalt starting from the center of the membrane to eliminate wrinkles.

8. Apply the hot asphalt at a min. 85% coverage at an area within 10' minimum of the perimeter and corners of the roof.

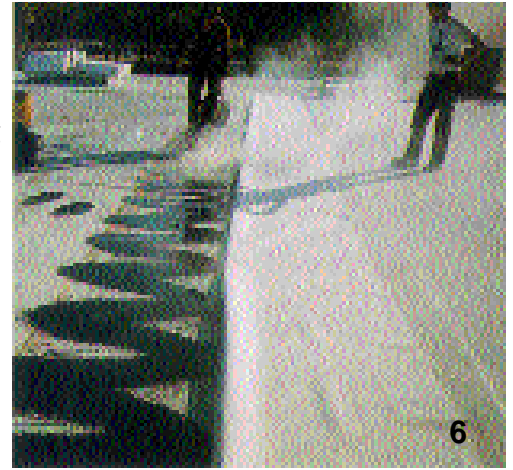

# Continuous Endlap Detail

1. Overlap the previous 60' courses of field sheet a minimum 2".
2. Center either the 7" or 14" double edge membrane over the overlap area.
3. Clean the areas under the laps using a clean, dry lint-free rag to assure the lap area of the double edge membrane is cleaned. (At least 8" for the 7" material and 15" for the 14" material.)
4. Remove the release paper and using a metal roller, firmly roll the seam.
5. Apply a 1/8" to 3/16" bead of GEOFLEX Paste 2" under each seam crossing and extend 1" past seam overlap.
6. Channel the Geoflex Paste into the "T" joint area, trapping the paste in the "T" joint area.
7. Backwipe the excess paste into the "T" joint after rolling.
8. **Do not squeeze out the paste from the lap areas.** Tool the GEOFLEX Paste at the "T" joint.
9. Caulk all seams installed against the slope (gutter detail). Tool neatly.

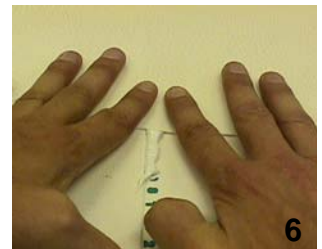
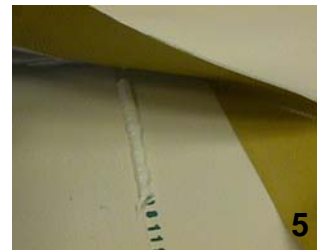
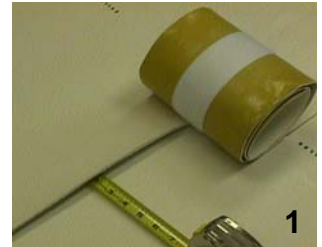

# Staggered Endlap Detail

1. Offset staggered endlaps a minimum of 5'.
2. Overlap the top membrane 2" onto the bottom membrane.
3. Cut off the bottom seam corner 2" at a 45 degree angle before removing the release paper.
4. Clean the top and bottom sheets a minimum of 6" wide centered over the lap and a minimum of 3" onto the adjacent sheet using a clean, dry lint-free rag.
5. Cut a 46" length of GEOFLEX 5" Cover Tape and round all corners.
6. Apply a 1/8" to 3/16" bead of GEOFLEX Paste to the overlap area 7" wide.
7. Remove the release paper from the GEOFLEX 5" Cover Tape.
8. Install without stretching, 2 1/2" on the top sheet and 2 1/2" on the bottom sheet.
9. The end of the 5" Cover Tape should extend a minimum of 2" onto the adjacent sheet.
10. Roll firmly using the GEOFLEX Seam Roller.
11. Roll both sides of GEOFLEX Paste to trap the paste in the "T" joint area.
12. **Do not squeeze the paste out of the "T" joint**, tool the extra paste neatly.



# Mitered Corner with a Cant Detail

1. Cut four (4) flashing sheets long enough to have the seam 3" on the flat of the deck at the outside of the cant.
2. Two of the sheets will overlap around 2" and the other two sheets butt flush at the corner.
3. Clean the seam areas using a clean, dry lint-free rag. Remove the release paper and roll firmly.
4. Apply GEOTAC Adhesive to the curb and membrane fleece at a rate of 75 sq. ft. per gallon on each surface. Mate together when dry to the touch.
  - a. Use GEOBOND Contact Flashing Adhesive as an alternative adhesive option in VOC restricted areas.
5. Install the two flashing sheets that overlap first, apply adhesive to the four areas of membrane that turn around the curb.
6. Install the other two sheets that butt flush in the corner.
7. Three pieces of 5" Cover Tape are needed to complete this corner detail.
8. Position bottom piece so that the "U" cut in the corner piece extends up the cant 1 1/2"
9. Roll firmly and apply GEOFLEX Paste to all overlap areas.
10. Install the second piece of 5" Cover Tape so that the "U" cut in the corner extends up the vertical 1 1/2".
11. Roll firmly then apply Geoflex Paste to the overlap areas.
12. Install the third piece of 5" Cover Tape to extend to the top of the flashing, roll firmly.
13. Neatly tool the Geoflex Paste back into the "T" joints.

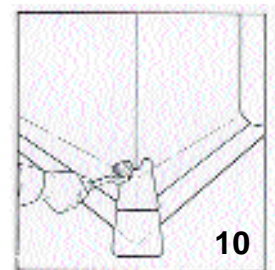
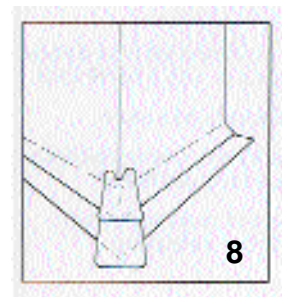
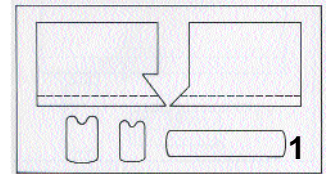

# Mitered Corner without a Cant Detail

1. Cut four (4) pieces of the GEOFLEX flashing sheet using the appropriate width membrane.
2. Two sides will wrap around the curb 2", the other two sides will be cut flush with the corner.
3. Apply GEOTAC Adhesive to the curb and membrane fleece at a rate of 75 sq. ft. per gallon on each surface. Mate together when dry to the touch.
  - a. Use GEOBOND Contact Flashing Adhesive as an alternative adhesive option in VOC restricted areas.
4. Clean the corner area using a clean, dry lint-free rag, then apply GEOFLEX Paste.
5. This detail will use a two (2) piece cover tape corner.
6. The first corner piece will have the "U" cut extend up the vertical 1/2" to 3/4".
7. Apply GEOFLEX Paste to all overlap areas, then roll firmly using a metal roller.
8. Install the second piece of GEOFLEX 5" Cover Tape from the deck transition to the top of the flashing.
9. Neatly tool the GEOFLEX Paste back into the "T" joints.

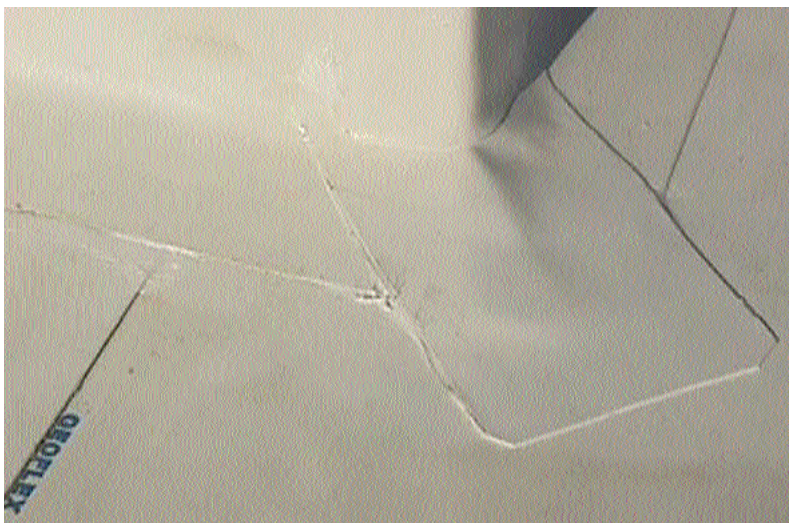
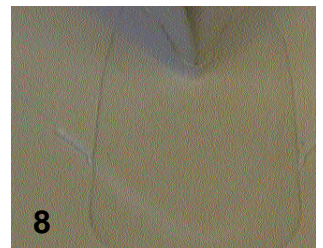
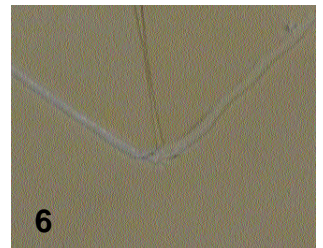
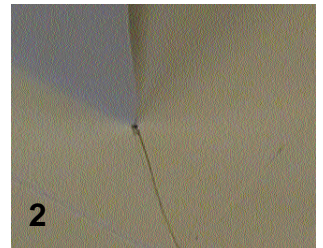
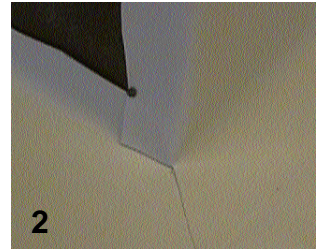

# Inside Corner Detail

1. Cut the GEOFLEX flashing sheet into the corner so that one side overlaps 2" and the other sheet butts flush into the corner.
2. Cut the membrane on the deck so the two sheets form a 45 degree angle into the corner.
3. Adhere the flashing to the wall using GEOTAC Adhesive. Connect the sealing edge to the field membrane after cleaning with a clean, dry lint-free rag.
  - a. Use GEOBOND Contact Flashing Adhesive as an alternative adhesive option in VOC restricted areas.
4. Without a cant this detail requires two (2) pieces of GEOFLEX 5" Cover Tape, with a cant requires a three (3) piece detail.
5. Cut the bottom piece of 5" Cover Tape long enough to extend a minimum of 3" past the seam and 2 1/2" up the transition.
6. Cut that piece in the center of the 5" width to a depth of 2 1/2" and form a cone that will fit into the corner.
7. Clean the area using a clean, dry lint-free rag, then apply GEOFLEX Paste to overlap the area.
8. Remove the release paper, install the 5" Cover Tape and roll firmly.
9. Apply GEOFLEX Paste to the top of the 5" Cover Tape.
10. Install the second piece of 5" Cover Tape from the top of the flashing to the deck and wall transition.
12. Roll the detail firmly using the Geoflex Seam Roller.
13. Tool all paste neatly back into the "T" joints.

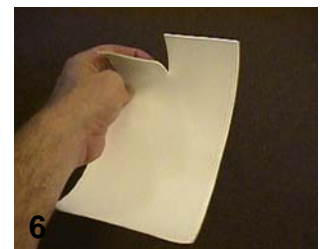
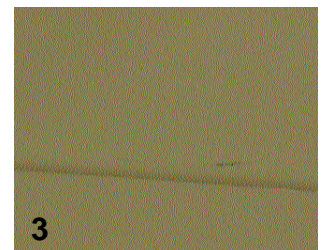

# Wall Flashing Detail

1. Select appropriate width flashing sheet. ( 14", 21", or 28" )

a. If wall height exceeds 36" (3 feet), the Geoflex 42" field sheet can be used for wall flashings. When running the sheets horizontally, the use of cap nails every 12" or the use of a flat termination bar fastened every 12" is required to ensure wall adhesive gains sufficient "green strength." Use additional cap nails or flat bars for every additional 42" flashing sheet.

2. Apply GEOTAC Adhesive to the wall at a rate of 75 sq.ft. per gallon.

a. Use GEOBOND Contact Flashing Adhesive as an alternative adhesive option in VOC restricted areas.

3. Apply Adhesive to the fleece backing at a rate of 75 sq. ft. per gallon

4. Adhere the GEOFLEX flashing sheet into the GEOTAC Adhesive when the adhesive is dry to the touch on both surfaces.

5. Wall flashings should be a minimum of 8" high above adjacent roof membrane.

6. Extend all base flashings approximately 3" to 4" onto the horizontal roof membrane.

7. Follow sheet seaming instructions to adhere the flashing to the roof membrane.

8. Terminate the wall flashing as appropriate per the project specifications.



# Wall Splice Lap Detail

1. After applying the specified width flashing membrane in adhesive, overlap the next section of wall flashing two (2") inches.
2. Without a cant detail, use two (2) pieces of 5" Cover Tape. With a cant detail, use three (3) pieces of 5" Cover Tape.
3. Cut the bottom seam in a 45 degree angle 2" from the end of the roll.
4. Clean the area of overlap using a clean, dry lint-free rag.
5. Apply a 1/8" bead of GEOFLEX Paste 7" wide at seam overlap.
6. Center the GEOFLEX 5" Cover Tape a minimum of 1" to 1 1/2" above the deck and wall transition and extending 2" beyond the seam.
7. Roll each side of the GEOFLEX Paste to trap it in the "T" joint, roll the remainder of the GEOFLEX 5" Cover Tape.
8. Apply a bead of GEOFLEX Paste to the top edge of the 5" Cover Tape.
9. Install the second piece of GEOFLEX Cover Tape from the top of the flashing to the deck and wall transition.
10. Tool all paste neatly back into the "T" joints.

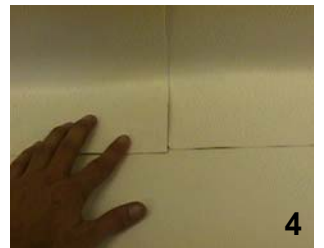
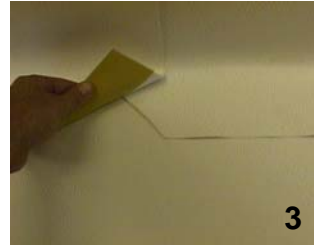
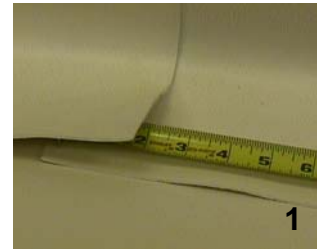

# Flashing to Cylindrical Penetrations

1. Thoroughly clean the penetration surface to be flashed.
2. Cut a collar of GEOFLEX Unreinforced membrane a minimum 5" larger than the penetration on all sides (a 4" diameter pipe requires a 14" collar).
  - Round all corners of the flashing sheet.
3. Cut a hole in the center of the collar 1/3 the diameter of the penetration.
4. Stretch the collar over the penetration allowing about 1 1/2" of the collar to remain turned up the penetration.
5. Apply Geoflex Primer to the penetration in one even coat at a rate of 16 to 20 wet mils being careful not to spill the primer on the Geoflex PIB collar.
6. Using a brush, solvent weld the collar to the field membrane with GEOFLEX Solvent.
7. Install the GEOFLEX 5" Cover Tape around the penetration to the deck transition, overlap the Cover Tape a minimum of 2".
8. At the overlap of the GEOFLEX 5" Cover Tape apply a continuous bead of GEOFLEX Paste.
9. Roll the GEOFLEX 5" Cover Tape with firm pressure.
10. Using Durathane Sealant, apply a bead to the top of the flashing and tool neatly.

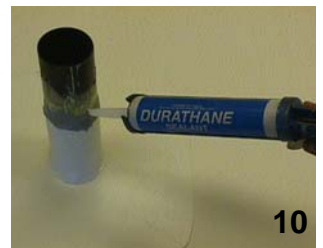
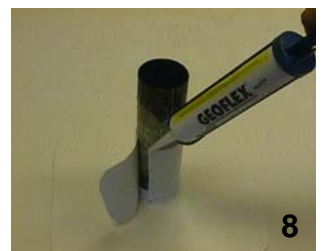
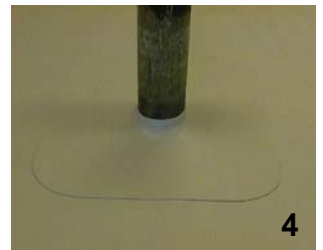

# Gravel Stop and Gutter Details

1. Fasten the GEOFLEX field membrane into the outside face of the nailer.

- Attach a continuous cleat to the face of the nailer, and clip on the fascia.
- Attach the flange into the nailer, fastening 3" O.C.

2. Prime the metal with GEOFLEX Primer in an even coat at a rate of 16 to 20 wet mils. Allow to dry thoroughly.

3. Using the GEOFLEX 7" double edge membrane, adhere one seam to the primed metal by pulling the release paper and rolling firmly.

4. Using a clean, dry lint-free rag, clean the membrane under the second seam.

5. Pull the release paper and roll firmly using the GEOFLEX Seam Roller.

6. On the metal edge side apply 1/4" bead of Durathane Sealant and tool neatly.

7. Apply a bead of GEOFLEX Paste to the other seam and tool neatly if the seam is against the water flow.

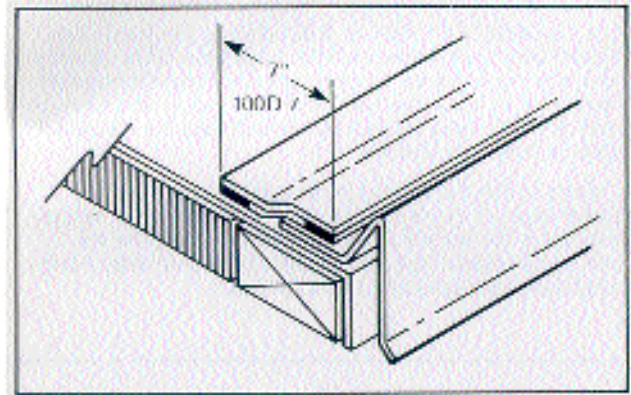

# Drain Flashing Detail

1. The GEOFLEX reinforced drain collar is a minimum 10" larger than the outside of the drain bowl in all directions.
2. Thoroughly clean the drain bowl to allow for a proper seal.
3. Cut the Geoflex field membrane to the outside edge of the drain bowl.
  - Do not take the field membrane into the drain assembly.
4. Apply two continuous ½" beads of Geoflex Drain Sealant around the entire drain bowl.
5. Install the Geoflex 28" reinforced collar into the drain assembly.
- 6. Secure the collar to the drain bowl using the clamping ring first, prior to solvent welding the collar to the field sheet.**
7. Equally tighten the clamping ring bolts.
8. Using GEOFLEX Solvent, weld the collar to the field sheet.
9. Using a solvent moistened brush, apply hand pressure to the collar and in a circular motion weld the two membranes together.
10. Check the drain collar for voids using a needle probe.
11. Apply a bead of GEOFLEX Paste to the outside edge of the drain collar, and tool neatly.
12. Re-attach the drain screen.
13. For a side view see Detail G-10 Roof Drain Flashing Revised 12-1-97. Detail drawings are available on-line at [www.rpmrepublic.com](http://www.rpmrepublic.com).

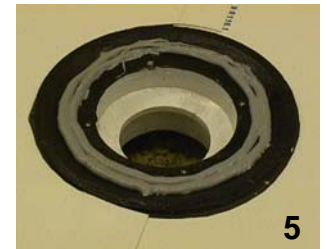
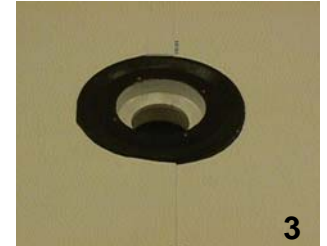
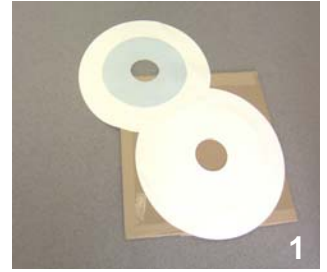

# Pitch Pocket Detail

- The pitch pocket needs to be a minimum of 4" in height with a 2 1/2" flange.

- The flange needs to have soldered closed corners

1. Attach the flange to the wood nailer.

2. Prime the metal with GEOFLEX Primer as previously described.

3. Clean the membrane using a clean, dry lint-free rag, then install the GEOFLEX 5" Cover Tape to the primed metal and the membrane, and roll firmly.

4. Repeat on all four sides, apply GEOFLEX Paste to all overlap areas and tool neatly.

5. Fill the bottom half of the pitch pocket with non-shrink grout.

6. Fill the top half using Pitch Pocket Sealant and crown the material.

7. Install a metal rain shield above the pitch pocket.

8. Apply a bead of Durathane around the pitch pocket at the edge of the membrane and the metal, also at the top edge of the rain shield.

9. Tool the Durathane neatly.

